

Data Sheet – PTFE Expansion Joint (non-braced) Guards

Ideal for Acid / Caustic / E115 Oil and Diesel mist prevention

The PTFE shield is manufactured from 3 layers of Teflon coated fibreglass, with an additional thick Teflon central scrim for added strength. All stitching is 100% Teflon coated fibreglass thread.

The easy to fit, lock tight, fastening system comprises a Velcro strip coupled with a braided 100% Teflon coated fibreglass draw string. When tightened, the fabric is drawn over the flange bolts toward the pipe wall thus eliminating a lateral spray out.

For a detailed quotation please confirm key dimensions “A” “B” & “C” below.

Specification

Material	:	PTFE
Stitching	:	PTFE
Draw strings	:	PTFE
Max. Temperature	:	232 Deg C
Flange Ratings	:	ANSI / DIN / BS
Sizes	:	½” to 48”
Leak Detection	:	Visual Litmus paper
Typical Applications	:	Oil (fuel,lube,seal, etc) Acids, Caustics, Corrosives

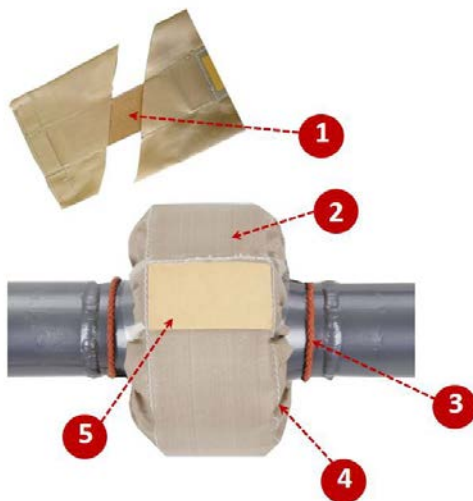
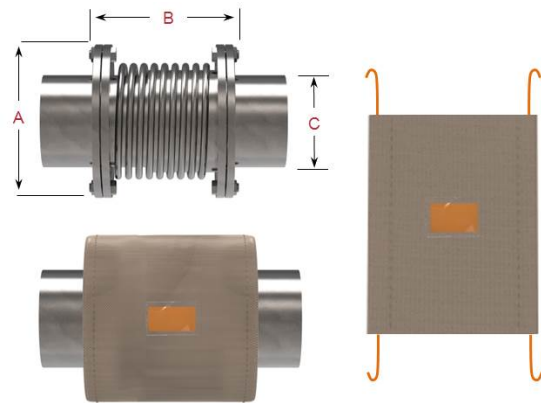

1. Central Thick Scrim Material

Added safety. Without this, a high pressure release can split the outer shield material, creating spray and mist.

2. Permeable Teflon Material

Ensures leaking liquid is drawn away from the flange, thus avoiding corrosion (especially in acid duty). Some “non-permeable” shield designs can hold corrosive liquids against the flange.

3. Teflon Coated Pull Cord

Provides a strong, re-usable tie down.

4. Teflon Thread

Better resistance against corrosive atmospheres. Other shields use cotton threads which disintegrate quickly.

5. Litmus Paper Indicator Patch

Quick, visual indication of a leak.

Flangeguards Ltd

Unit 5, Cranes Close,
Basildon,
Essex, SS14 3JB
01268 244369
sales@flangeguards.com

Delivery

Most shield materials and sizes are available ex-stock; however, in case of low availability delivery may take 2 - 4 working weeks.

Call 01268 244369 to confirm current stock levels –or e-mail sales@flangeguards.com